

Manual Handle Type Incremental Rotary Encoder

■ Features

- Suitable for manual pulse input type such as numerically controlled or milling machinery
- Terminal connection type
- Power supply: 5VDC ±5%, 12-24VDC ±5%

■ Applications

- Industrial tooling machinery



⚠ Please read "Safety Considerations" in the instruction manual before using.



■ Ordering Information

ENH – **100** – **1** – **T** – **24**

Series	Pulses/revolution	Clickstopper position	Control output	Power supply
Handle type	25, 100	1: Normal "H" 2: Normal "L"	T: Totem pole output V: Voltage output L: Line driver output (※)	5: 5VDC ±5% 24: 12-24VDC ±5%

※The power of Line driver is only for 5VDC.

■ Specifications

Item	Manual Handle Type Incremental Rotary Encoder		
Resolution (PPR) ^{※1}	25, 100		
Electrical specification	Output phase	A, B phase (line driver output A, \bar{A} , B, \bar{B} phase)	
	Phase difference of output	Phase difference between A and B: $\frac{T}{4} \pm \frac{T}{8}$ (T= 1 cycle of A phase)	
	Control output	Totem pole output	• [Low] - Load current: max. 30mA, Residual voltage: max. 0.4VDC= • [High] - Load current: max. 10mA Output voltage (power voltage 5VDC=): min. (power voltage-2.0)VDC= Output voltage (power voltage 12-24VDC=): min. (power voltage-3.0) VDC=
		Voltage output	Load current: max. 10mA, Residual voltage: max. 0.4VDC=
		Line driver output	• [Low] - Load current: max. 20mA, Residual voltage: max. 0.5VDC= • [High] - Load current: max. -20mA, Output voltage: min. 2.5VDC=
	Response time (rise/fall)	Totem pole output	Max. 1μs (cable length: 1m, I sink = 20mA)
		Voltage output	
		Line driver output	Max. 0.2μs (cable length: 1m, I sink = 20mA)
	Power supply	• 5VDC= ±5% (ripple P-P: max.5%) • 12-24VDC= ±5% (ripple P-P: max.5%)	
	Current consumption	Max. 40mA (disconnection of the load), Line driver output: max. 50mA (disconnection of the load)	
	Max. response frequency	10kHz	
	Insulation resistance	Over 100MΩ (at 500VDC megger between all terminals and case)	
	Dielectric strength	750VAC 50/60Hz for 1 minute (between all terminals and case)	
Connection	Terminal block type		
Mechanical specification	Starting torque	Max. 1kgf·cm (0.098N·m)	
	Shaft loading	Radial: max. 2kgf, Thrust: max. 1kgf	
	Max. allowable revolution ^{※2}	Max. 200rpm (normal), 600rpm (peak)	
Vibration	1.5mm amplitude at frequency of 10 to 55Hz (for 1 min) in each X, Y, Z direction for 2 hours		
Shock	Approx. max. 50G		
Environment	Ambient temperature	-10 to 70°C, storage: -25 to 85°C	
	Ambient humidity	35 to 85%RH, storage: 35 to 90°C	
Protection structure	IP50 (IEC standard)		
Approval	CE (except for line driver output)		
Weight ^{※3}	Approx. 330g (approx. 260g)		

※1: Not indicated resolutions are customizable.

※2: Make sure that max. response revolution should be lower than or equal to max. allowable revolution when selecting the resolution.

$$[\text{Max. response revolution (rpm)}] = \frac{\text{Max. response frequency}}{\text{Resolution}} \times 60 \text{ sec}$$

※3: The weight includes packaging. The weight in parenthesis is for unit only.

※Environment resistance is rated at no freezing or condensation.

SENSORS

CONTROLLERS

MOTION DEVICES

SOFTWARE

(A) Photoelectric Sensors

(B) Fiber Optic Sensors

(C) LIDAR

(D) Door/Area Sensors

(E) Vision Sensors

(F) Proximity Sensors

(G) Pressure Sensors

(H) Rotary Encoders

(I) Connectors/ Connector Cables/ Sensor Distribution Boxes/ Sockets

ENH Series

Control Output Diagram

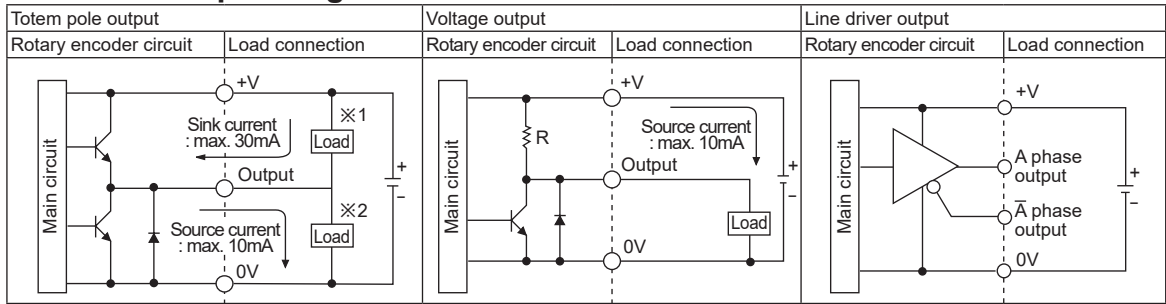

- The output circuits for A, B phase (line driver output is A, \bar{A} , B, \bar{B} phase) are same.
- Totem pole output can be used for NPN open collector type (※1) or voltage output type (※2).

Output Waveform

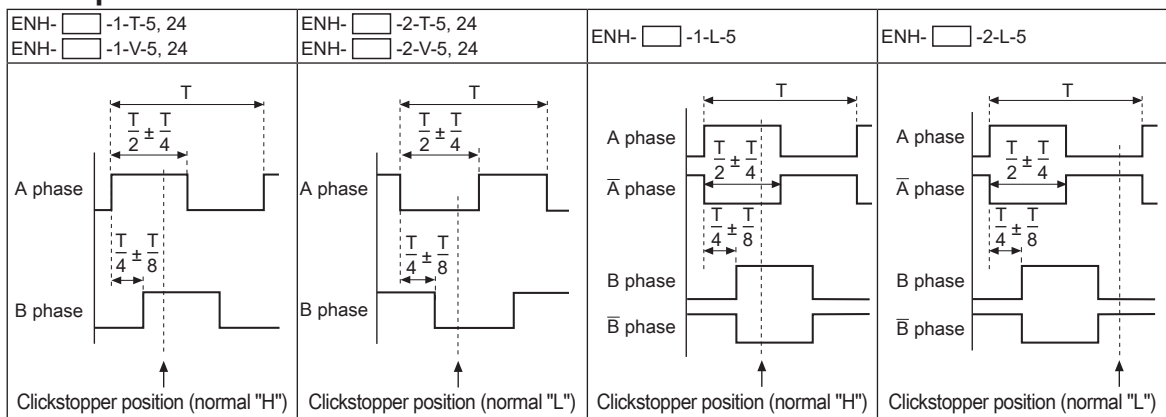

※Clickstopper position Normal "H" or Normal "L": It shows the waveform when the handle is stopped.

Connections

•Totem pole output / Voltage output

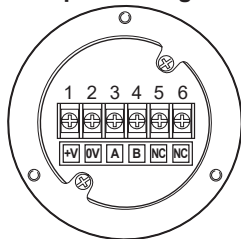

※Do not use terminal No. 5, 6.

•Line driver output

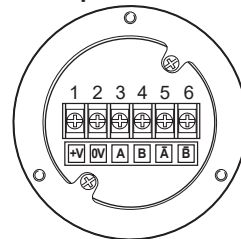

Dimensions

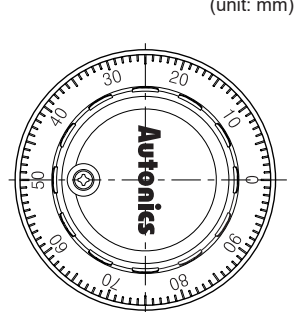
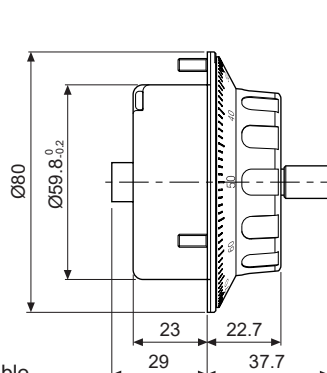
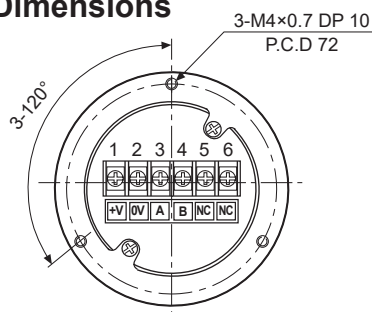

(unit: mm)

- ※Ø70mm P.C.D mounting hole type is customizable.
- ※Fix the unit or a coupling by a wrench under 0.15N·m of torque.